



Dual Chamber  
Orifice Fitting  
**TECHNICAL  
CATALOG**



**Precisionflow**

# CONTENTS

Page 4	Company Profile
Page 6	Special Features
Page 9	Installation
Page 12	Size, Weights, and Dimensions
Page 20	Dual Chamber Orifice Fittings
Page 21	Exploded Parts View
Page 23	Design Factors by Location and Construction
Page 25	Seal Rings - AGA 3 14.3 Latest Edition
Page 27	Precision Del Seal 2.0



# ABOUT PRECISION FLOW



Precision Flow is a leading provider of flow measurement solutions and services that is committed to delivering exceptional customer service, US-made products quality, and overall quality. We have a team of experienced experts who possess extensive knowledge of the flow measurement industry and are dedicated to helping our clients find the right solutions for their needs.

At Precision Flow, we take pride in offering a wide range of high-quality products and services: electronic flow meters, orifice fittings, meter tubes, borescope inspections, and meter tube cleans. We are known for our expertise in orifice fitting repairs and servicing, and we repair all orifice fitting brands.

Our commitment to quality is reflected in everything we do, from the materials we use to the manufacturing process and the final products we deliver. We stand by the quality of our products and services and offer quick lead times to ensure our clients receive the best service possible.

At Precision Flow, we also believe in the importance of exceptional customer service. Our team is dedicated to providing our clients with personalized attention and support, and we work closely with them to understand their needs and recommend the right solutions.

**Proudly Manufactured and Assembly in Odessa, TX USA**

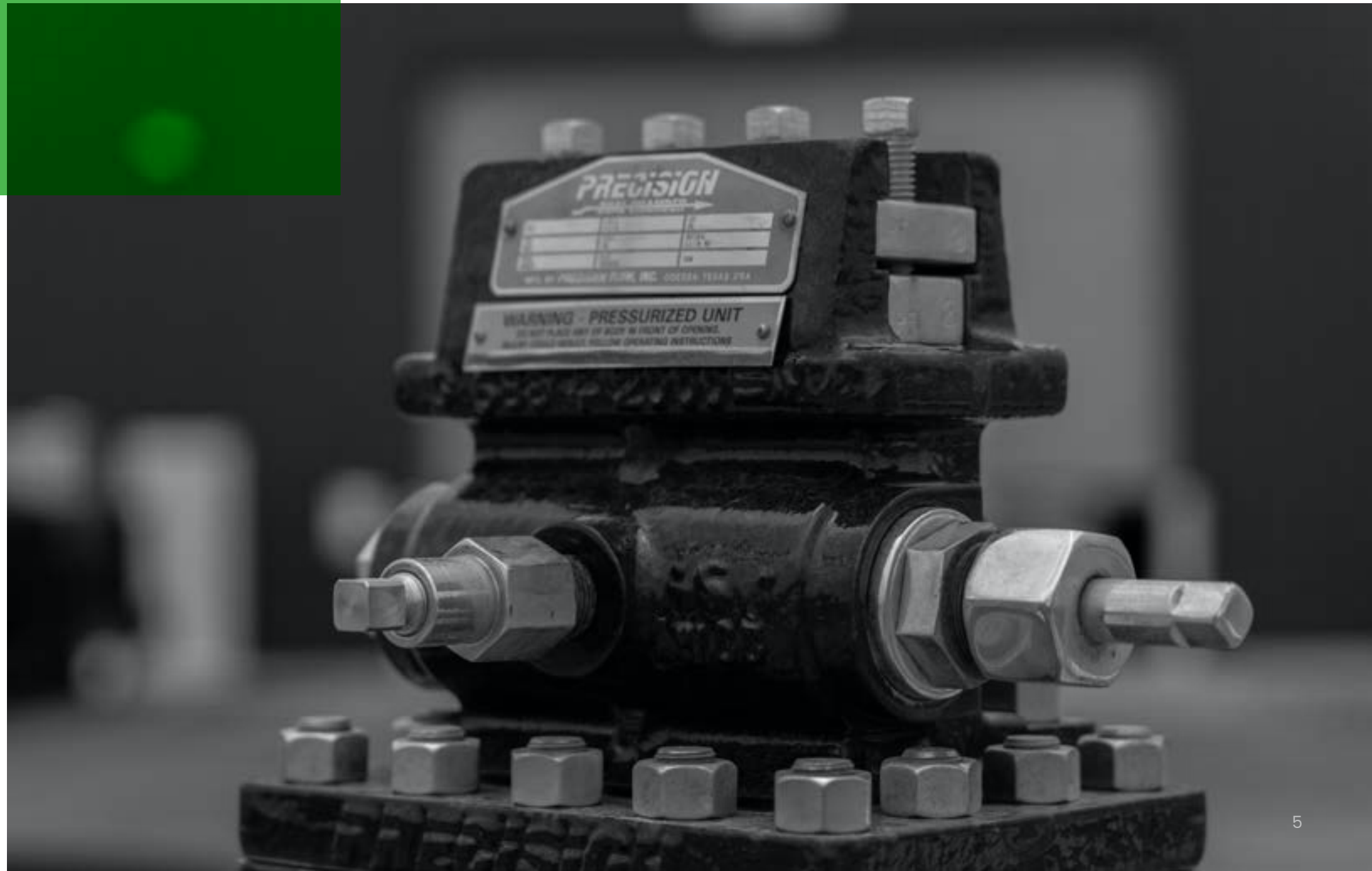

# SPECIAL FEATURES

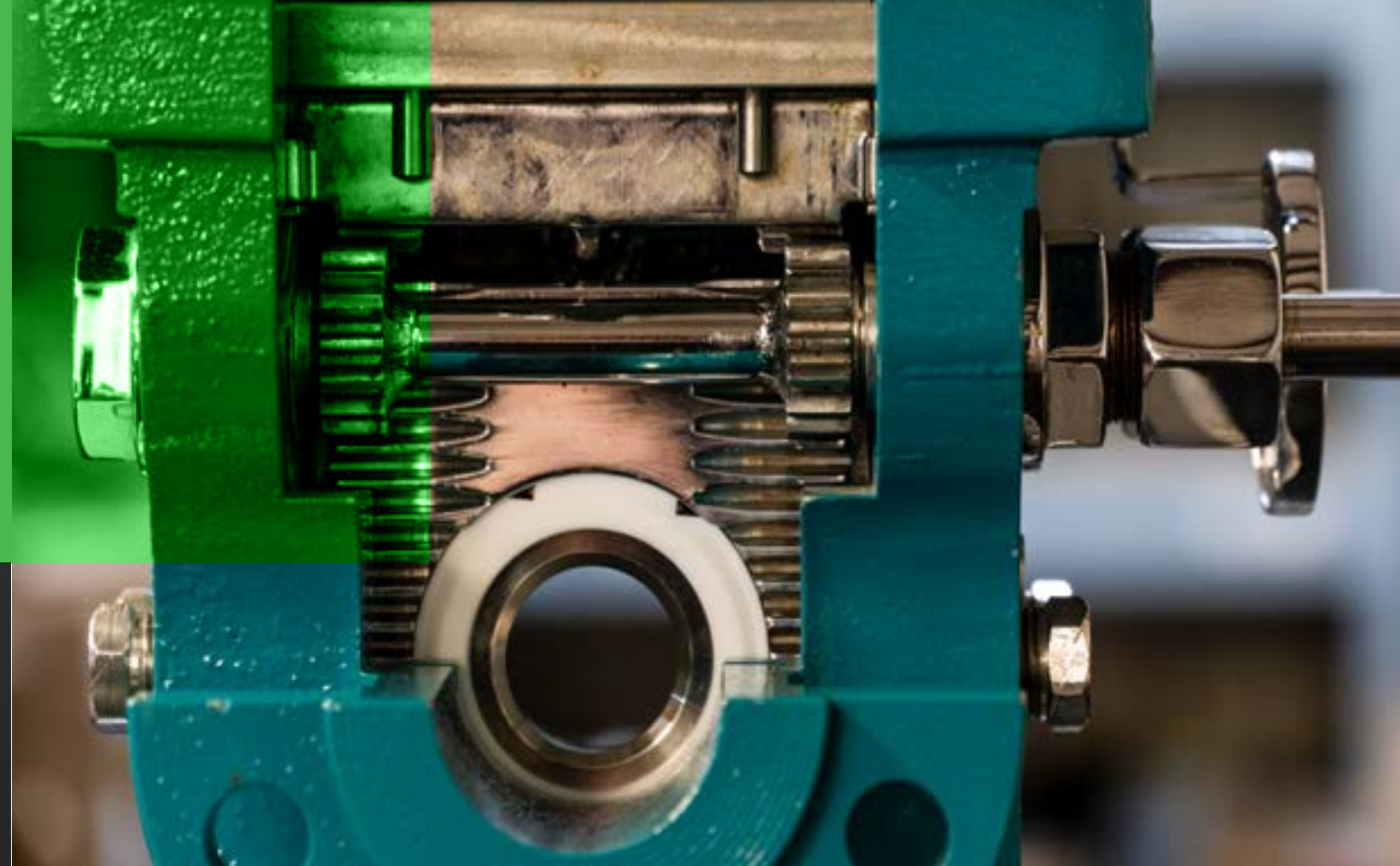

## **ORIFICE PLATE SEALING UNITS**

Provide a secure seal between the orifice plate and body seats, suitable for a variety of applications.

## **PLATE CARRIER**

Ensures continuous protection for the orifice plate during insertion and removal from the fitting.

## **INDICATOR PLATE**

Clearly displays the valve position within the fitting for easy operation and monitoring.

## **TEFLON SHAFT PACKING AND CENTERING RINGS**

Included as standard components on all Precision Dual Chamber fittings, available in all sizes and pressure ratings.

## **VERSATILE FITTINGS**

Fittings up to 6" line size can be operated in a vertical up-flow position or in horizontal flow for side openings.

## **COMPACT DESIGN**

Optimized for minimal operating space, offering efficient functionality.

## **ENGINEERED TO STANDARDS**

All Dual Chamber Orifice Fittings are designed and manufactured in compliance with the latest ANSI, API, and AGA recommendations, adhering strictly to A.S.T.M. specifications.

# SPECIAL FEATURES

## Precision Method of Aligning Meter Tube Flange to Orifice Fitting Flange

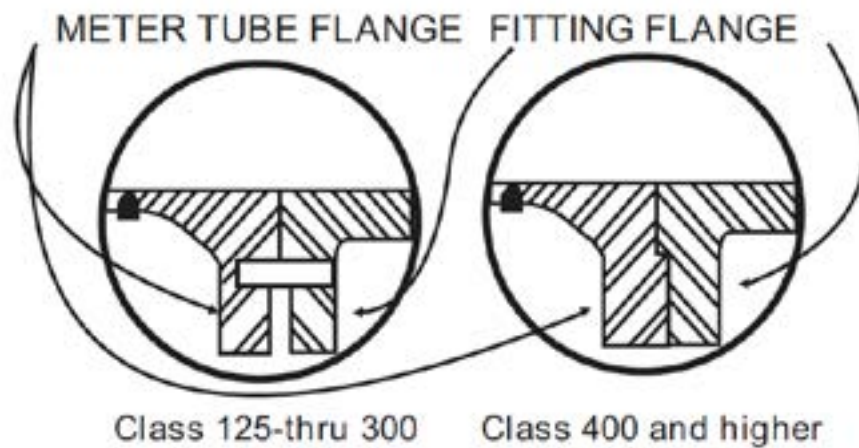

On all sizes, ANSI Class 300 or under, three dowel pin flange-alignment holes are drilled in the flanges.

Class 400 or higher, companion flanges are manufactured with close-tolerance, square-shouldered, large male flange-facing on fitting and large female flange-facing on meter tube to assure proper internal alignment. Flange gaskets are precision-cut so that under compression they will not extend into internal bore of fitting. Refer to engineering drawing above.

## SLIDE VALVE DETAIL

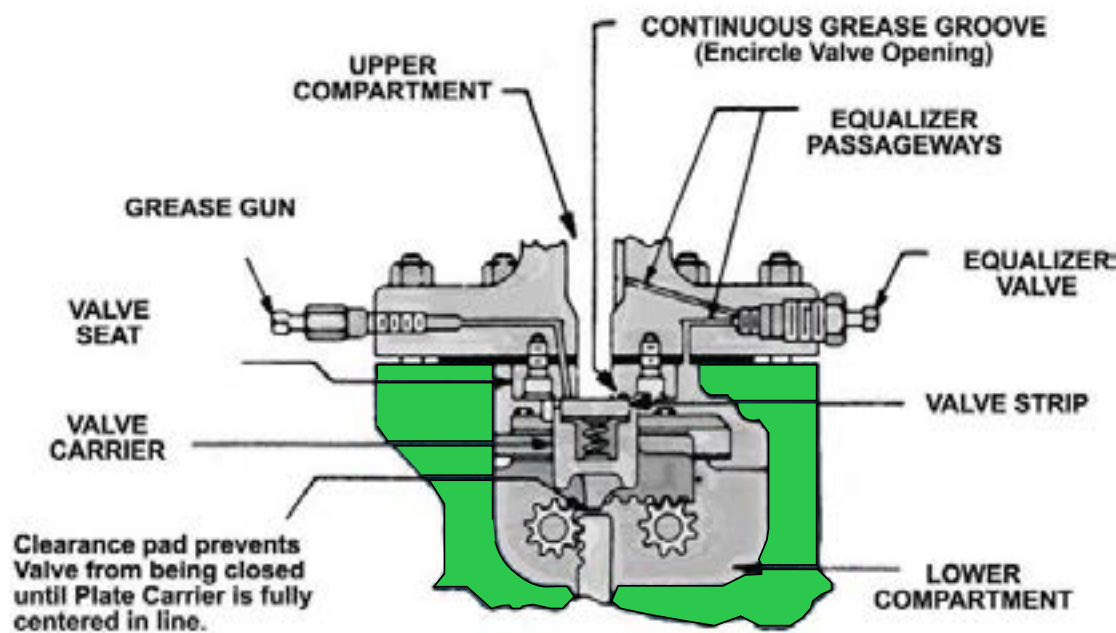

In Precision Dual Chamber Orifice Fittings, the valve seat is a part of the upper chamber. The valve strip moves underneath this seat, thus utilizing line pressure to effect a positive seal. The valve strip is maintained in "floating" position by minimum spring pressure. Before slide valve is opened, it is lubricated through grease gun. Pressure is then equalized throughout the entire fitting by operation of the equalizer valve. Equalized pressure on both sides of the valve strip allows slide valve to move freely without wear. Valve seat and valve strip are ground for tight shut-off and are easily removable for grinding if required.

# INSTALLATION

1. Remove all foreign matter such as dirt, sediment or scale from fitting surfaces, connections and internal cavities which may have collected between factory inspection and delivery Gasket the line flanges and install or weld the fitting line, making sure flow arrow cast on body corresponds to flow direction
2. Install Bleeder Valve (Part No.10B) and Grease Gun (Part No. 23) to connections provided on fitting.
3. Fitting is shipped with Slide Valve open. Remove Slide Valve Indicator Plate (Part No. 5A) and Slide Valve Indicator Pointer (Part No.5B) from sack and (position Indicator Plate on Slide Valve Shaft Part No.5) with the word OPEN at 12 o'clock position. Tighten set screw to fix plate on shaft. Use two drive screws to install Indicator Pointer on fitting body, as shown below, so that it points to the word OPEN on Plate.
4. When fitting is shipped, the Plate carrier (Part No.8DM) is enclosed inside and the Orifice Plate is packaged separately.
5. After installation, remove Drain Plugs ( Part No.30). Check for any foreign matter that may have been trapped in fitting cavities. Install full-opening valves for blow - down operation.

## CAUTION

Precision, Dual Chamber Orifice Fittings are operated under pressurized line conditions. Proper precautions must be exercised to protect personnel. Always follow OPERATING instructions and avoid placing any part of the body in front of the top opening when the clamping bar is removed.

## To Remove Orifice Plate

- (A) Open No. 1 (Max. Two Turns Only)
- (B) Open No. 5
- (C) Rotate No.6
- (D) Rotate No. 7
- (E) Close No. 5
- (F) Close No. 1
- (G) Open No. 10B
- (H) Lubricate thru No. 23
- (I) Loosen No. 11 (DO NOT Remove No. 12)
- (J) Rotate No. 7 to Free No 9 and 9a
- (K) Remove No. 12, 9 and 9A

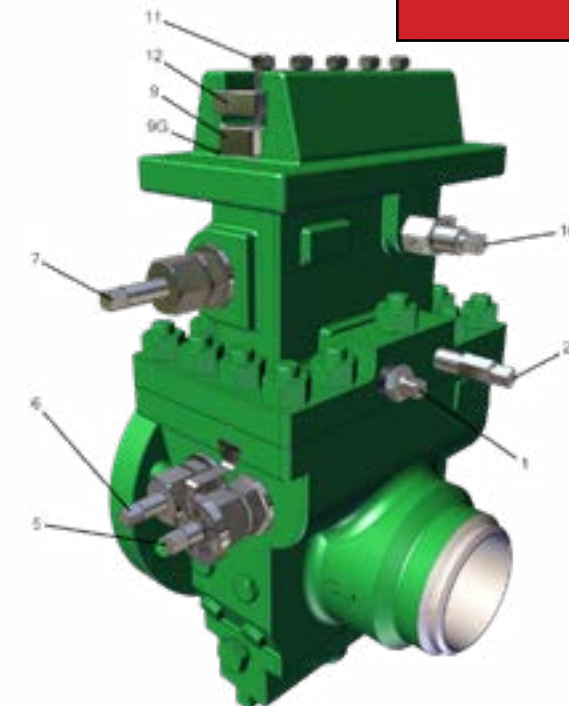

## To Replace Orifice Plate

- (A) Close 10B
- (B) Rotate No. 7 slowly until Plate Carrier is clear of Sealing Bar and Gasket level. Do not lower until Carrier onto Slide Valve.
- (C) Replace No. 9A, 9 and 12
- (D) Tighten No. 11 Open No. 1.
- (E) Open No. 5
- (F) Rotate No. 7
- (G) Rotate NO. 6 Close No. 5
- (H) Close No. 1 Open 10B
- (I) Lubricate thru No. 23 Close No. 10B and 9A

## MAINTENANCE

1. It is recommended that all Dual Chamber Orifice Fittings be operated once every thirty days. Slide valve should be opened and closed and lubricant should be applied through grease gun.
2. If plate inspection is not required, rotate operating shafts anyway.
3. In conditions where foreign matter accumulates, blow-down valves (as per installation instruction No.5) should be used to clear dirt from fittings as often as required.
3. Plate Carrier should always be raised into upper chamber before blowing or cleaning through blow- down valves.
4. When pigging the line, a pigging ring is recommended for use to prevent dirt from being forced into the plate carrier cavity.
5. Following the pigging operation, the blow-down valve(s) should be opened to clear out any accumulation of dirt which may have been forced

# NOTES

- \* All Fittings come with SS (NACE COMPLIANT) trim
- \* Fittings come with Grease Gun, Equalizer Valve, Bleeder Valve Installed
- \* Orifice Plate Rubber (HNBR, Teflon (PTFE) Packing, and Rubber-Teflon-Metal Seals) Seal Ring sold separately
- \* SS Orifice Plates, Grease, Teflon, or Metal Seals are not included and sold separately. Please ask the sales representative for pricing and availability.

\*\*Precision Flow offers high-pressure 1500# fitting lines in sizes 2" through 12". We also offer larger 150-600# fitting sizes in 16", 18", 20", and 24". These fittings can be in your Traditional Flangnek style, and the Flange X Flange style. If you are needing assistance over a quote for these fittings sizes, repair parts, or GA Drawing please contact sales@precisionflow.com.\*\*



## FITTING CLASS AND STYLE

RF(FN) =	011 - 150# 013 - 300# 015 - 600# 016 - 900# 017 - 1500# 018 - 2500#
RTJ (FN) =	0145- 600# 0146 - 900# 0147 - 1500# 0148 - 2500#
R FX RF (FXF)=	101 - 150# 103 - 300# 105 - 600# 106 - 900# 107 - 1500# 108 - 2500#
RTJ X RTJ (FXF)=	145 - 600# 146 - 900# 147 - 1500# 148 - 2500#
WeldXWeld (WN) =	185 - (150#-600#) 186 - 900# 187 - 1500# 188 - 2500#

## FITTING

## SIZE

## PIPE SCHEDULE

## BODY MATERIALS

**Note:** Standard body materials are A216 or A352 Dual Grade. If alternate materials are used, they will be specified in the fitting description provided on the quote.

## DUAL CHAMBER (DC)

2 - 2"  
3 - 3"  
4 - 4"  
6 - 6"  
8 - 8"  
10 - 10"  
12 - 12"  
14 - 14"  
16 - 16"  
18 - 18"  
20 - 20"  
24 - 24"

Sch. 40 = 1  
Sch. 80 = 2  
Sch. 100 = 3  
Sch. 120 = 4  
Sch. 160 = 5  
Others = Schedule Number  
Ex: 12" S/60 = 60  
12" S/XS = XS  
\*If special bores are needed the actual special line size will be at the end.  
EX: 015DC-10-9.750

A216 WCC	-	A216/A352 (Standard Dual Grade Casting)
A352 LCC	-	A216/A352 (Standard Dual Grade Casting)
A437 4C	-	A437
A358 CF8M	-	A358
A890 CD3MN (2250 Duplex)	-	2250
*Other Special Materials Upon Request	-	Based On Material and Grade

EX: 015DC-4-2  
4" 600# S/80 (3.826" ID) A-216WCC Precision  
Dual Chamber Fitting Only

# Standard RF FLANGENEK (FN) FITTINGS

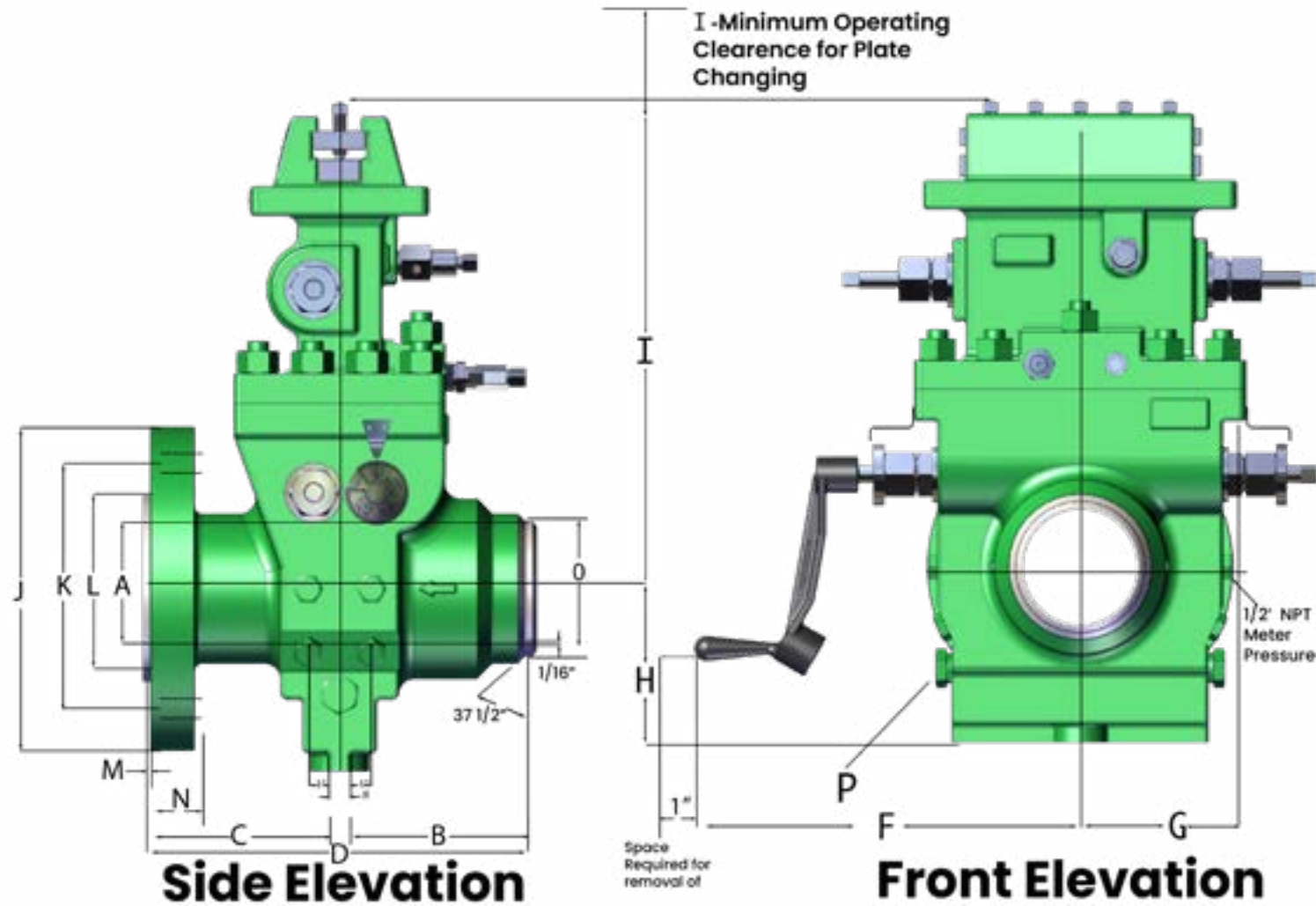

# SIZE, WEIGHTS, AND DIMENSIONS

SIZE	A	B	C	D	E	F	G	H	I	J	K	L	M	N			P	R	
------	---	---	---	---	---	---	---	---	---	---	---	---	---	---	--	--	---	---	--

Catalog No. 011DC • 150 Lb. A.S.A. • "FLANGE x WELD" Standard Flange Facina • 285 P.S.I. (Gage) C.W.P. • Dual Seal																				
2..	2.067	5.312	5.312	10.625	12.875	4.250	3.750	13.250	5.562	6.000	4.750	3.625	.062	.750	4 @ .625	3.250	2.375	.500	.125	105
3..	3.068	5.375	5.375	10.750	13.750	5.375	4.000	14.500	6.062	7.500	6.000	5.000	.062	.937	4 @ .625	3.750	3.500	.500	.125	150
4..	4.026	5.500	5.500	11.000	14.125	5.875	4.500	15.750	7.000	9.000	7.500	6.188	.062	.937	8 @ .625	3.750	4.500	.750	.125	200
6..	6.065	6.625	6.625	13.250	15.500	6.750	5.500	18.750	9.000	11.000	9.500	8.500	.062	1.000	8 @ .750	4.000	6.625	.750	.125	330
8..	7.981	6.250	6.250	12.500	16.500	8.000	6.750	21.750	11.000	13.500	11.750	10.625	.062	1.125	8 @ .750	4.250	8.625	.750	.250	480
10..	10.020	6.500	6.500	13.000	17.375	9.000	8.000	24.875	13.125	16.000	14.250	12.750	.062	1.187	12 @ .875	4.750	10.750	.750	.250	615
12..	11.938	7.500	6.500	14.000	18.875	10.750	9.500	28.000	15.000	19.000	17.000	15.000	.062	1.250	12 @ .875	4.750	12.750	.750	.250	1110

Catalog No. 013DC • 300 Lb. A.S.A. • "FLANGE x WELD" Standard Flange Facing • 740 P.S.I. (Gage) C.W.P. • Dual Seal																				
2..	2.067	5.312	5.312	10.625	12.875	4.250	3.750	13.250	5.562	6.500	5.000	3.625	.062	.875	8 @ .625	3.500	2.375	.500	.125	1110
3..	3.068	5.562	5.562	11.125	13.750	5.375	4.125	14.500	6.062	8.250	6.625	5.000	.062	1.125	8 @ .750	4.250	3.500	.500	.125	155
4..	4.026	6.312	5.687	12.000	14.125	5.875	5.000	15.750	7.000	10.000	7.875	6.187	.062	1.250	8 @ .750	4.500	4.500	.750	.125	210
6..	6.065	7.000	7.000	14.000	15.500	7.000	6.250	18.750	9.000	12.500	10.625	8.500	.062	1.437	12 @ .750	4.750	6.625	.750	.125	340
8..	7.981	7.000	7.000	14.000	16.500	8.000	7.500	21.750	11.000	15.000	13.000	10.625	.062	1.625	12 @ .875	5.500	8.625	.750	.250	490
10..	10.020	8.250	7.250	15.500	17.375	9.000	8.750	24.875	13.125	17.500	15.250	12.750	.062	1.875	16 @ 1.000	6.750	10.750	.750	.250	650
12..	11.938	9.000	8.000	17.000	18.875	10.750	10.250	28.000	15.000	20.500	17.750	15.000	.062	2.000	16 @ 1.125	6.750	12.750	.750	.250	1135

Catalog No. 015DC • 600 Lb. A.S.A. • "FLANGE x WELD" Standard Flange Facing • 1480 P.S.I. (Gage) C.W.P. • Dual Seal																				
2..	2.067	5.312	5.312	10.625	12.875	4.250	3.750	13.250	5.562	6.500	5.000	3.625	.250	1.250	8 @ .625	4.250	2.375	.500	.125	110
3..	3.068	6.687	6.687	13.375	13.750	5.375	4.125	14.500	6.062	8.250	6.625	5.000	.250	1.500	8 @ .750	5.000	3.500	.500	.125	170
4..	4.026	6.625	6.625	13.250	14.125	6.125	5.375	15.750	7.000	10.750	8.500	6.188	.250	1.750	8 @ .875	5.750	4.500	.750	.125	280
6..	6.065	8.000	8.000	16.000	15.500	7.000	7.000	18.750	9.000	14.000	11.500	8.500	.250	2.125	12 @ 1.000	6.750	6.625	.750	.125	420
8..	7.981	8.750	8.750	17.500	16.500	8.000	8.250	21.750	11.000	16.500	13.750	10.625	.250	2.437	12 @ 1.125	7.750	8.625	.750	.250	625
10..	10.020	9.125	8.125	17.250	17.375	9.000	10.000	24.875	13.125	20.000	17.000	12.750	.250	2.750	16 @ 1.250	8.500	10.750	.750	.250	785

Catalog No. 016DCT • 900 Lb. A.S.A. • "FLANGE x WELD" Standard Flange Facing • 2220 P.S.I. (Gage) C.W.P. • Dual Seal																				
2..	*	7.000	7.000	14.000	12.875	5.750	4.250	13.750	5.562	8.500	6.500	3.625	.250	1.750	8 @ .875	5.750	2.375	.500	.125	185
3..	*	7.000	7.000	14.000	13.750	5.375	4.750	14.500	6.062	9.500	7.500	5.000	.250	1.750	8 @ .875	5.750	3.500	.500	.125	200
4..	*	7.875	7.125	15.000	14.125	6.125	5.750	15.750	7.000	11.500	9.250	6.188	.250	2.000	8 @ 1.125	6.750	4.500	.750	.125	300
6..	*	8.625	8.000	16.625	15.500	7.000	7.500	18.750	9.000	15.000	12.500	8.500	.250	2.437	12 @ 1.125	7.750	6.625	.750	.125	490
8..	*	9.187	9.187	18.375	17.250	9.125	9.250	21.750	11.000	18.500	15.500	10.625	.250	2.750	12 @ 1.375	8.750	8.625	.750	.250	1100
10..	*	10.937	10.937	21.875	18.375	11.000	10.750	24.875	13.125	21.500	18.500	12.750	.250	3.375	16 @ 1.375	9.250	10.750	.750	.250	1560
12..	*	11.687	11.687	23.375	20.375	12.000	12.000	28.000	15.000	24.000	21.000	15.000	.250	3.625	20 @ 1.375	10.000	12.750	.750	.250	1950

\*To be specified by purchaser.  
Size 12" up to 900 lbs. A.S.A. use " DVS" Seal Vulcanized to plate. Rev. 10.25

The dimensions shown in the table are approximations and are for guidance purposes only. Casting and machining tolerances may vary from published sizes. Refer to the sales personnel over the order to confirm specific fitting sizing, and or provide a GA Drawing.

# RTJ FLANGE (FN) FITTINGS

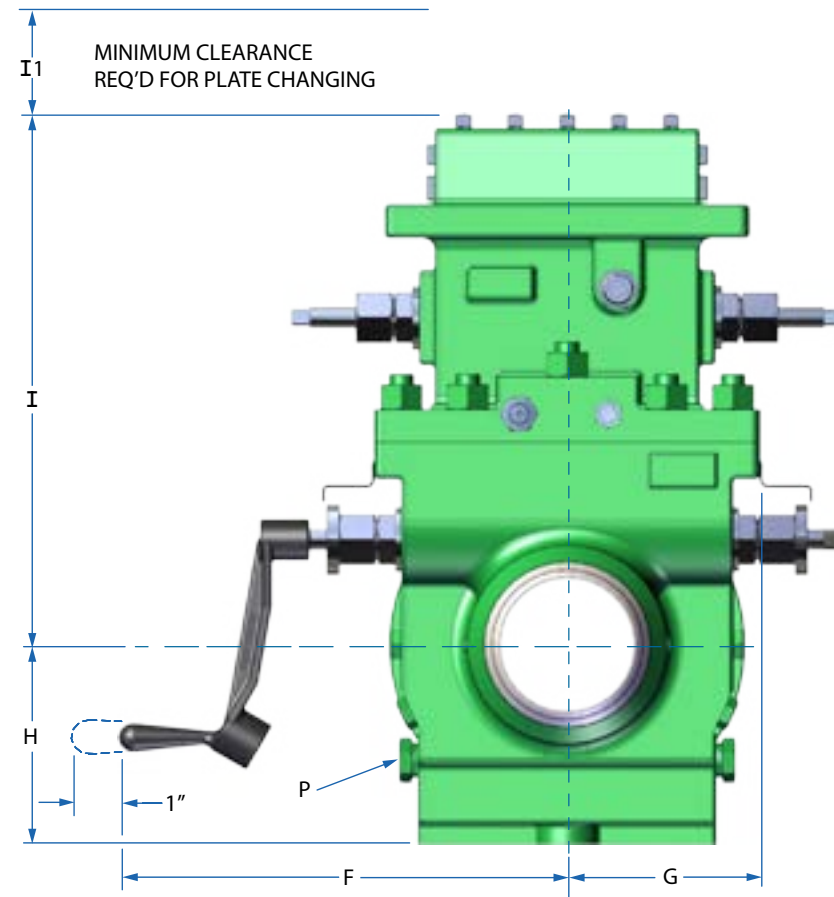
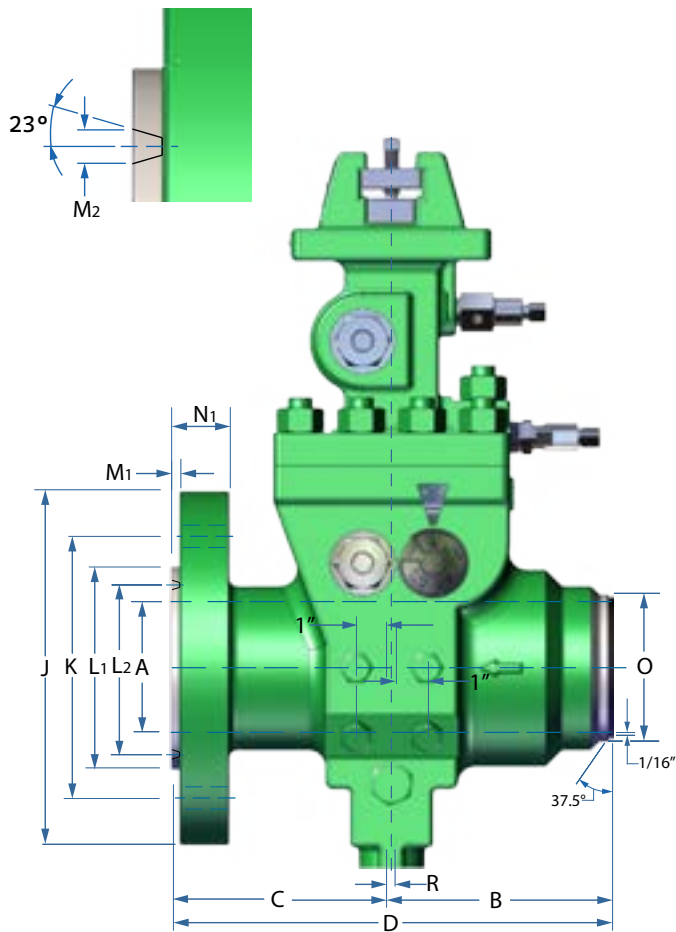

SIZE	API Ring Number	Internal Line Bore Diam.	Upstream Face of Orifice Plate to Face of End	Downstream Face of Orifice Plate to Face of End	Face to Face Overall Diam.	Operating Clearance From Center	Body Clearance From Center	Centerline to Bottom	Centerline to Top	Clearance For Changing Plate	Flange Diameter	Bolt Circle Diameter	Ring and Groove Pitch Diameter	Groove Depth	Groove Width	Flange Thickness	Number and Diameter of Bolt-Studs (Per Flange)	Length of Bolt-Studs with 2H Nuts Thickness	Diameter of Hub at Point of Welding	Drain Plug Size	Orifice Plate Thickness	Weight (Pounds) Approximate
		A	B	C	D	F	G	H	I	J	K	L2	M1	M2	N1			O	P	R		

Catalog No. 0145DC - 600 Lb. A.S.A. - "FLANGE x WELD" Ring-Joint Flange Facing - 1480 P.S.I. (Gage) C.W.P. - Dual Seal																						
2...	R-23	2.067	5.375	5.375	10.750	12.875	4.250	3.750	13.250	5.562	6.500	5.000	3.250	.312	.468	1.312	8 @ .625	4.500	2.375	.500	.125	105
3...	R-31	3.068	7.375	6.750	14.125	13.750	5.375	4.125	14.500	6.062	8.250	6.625	4.875	.312	.468	1.562	8 @ .750	5.250	3.500	.500	.125	160
4...	R-37	4.026	6.687	6.687	13.375	14.125	6.125	5.375	15.750	7.000	10.750	8.500	5.875	.312	.468	1.812	8 @ .875	6.000	4.500	.750	.125	265
6...	R-45	6.065	8.062	8.062	16.125	15.500	7.000	7.000	18.750	9.000	14.000	11.500	8.312	.312	.468	2.187	12 @ 1.000	7.000	6.625	.750	.125	400
8...	R-49	7.981	8.813	8.813	17.625	16.500	8.000	8.250	21.750	11.000	16.500	13.750	10.625	.312	.468	2.500	12 @ 1.125	8.000	8.625	.750	.250	595
10...	R-53	10.020	9.187	8.187	17.375	17.375	9.000	10.000	24.875	13.125	20.000	17.000	12.750	.312	.468	2.812	16 @ 1.250	8.750	10.750	.750	.250	745
12...	R-57	11.938	10.000	9.000	19.000	18.875	10.750	11.000	28.000	15.000	22.000	19.250	15.000	.312	.468	2.937	20 @ 1.250	9.000	12.750	.750	.250	1215

Catalog No. 0146DC - 900 Lb. A.S.A. - "FLANGE x WELD" Ring-Joint Flange Facing - 2220 P.S.I. (Gage) C.W.P. - Dual Seal																						
2...	R-24	*	7.062	7.062	14.125	12.875	5.750	4.250	13.750	5.562	8.500	6.500	3.750	.312	.468	1.812	8 @ .875	6.000	2.375	.500	.125	205
3...	R-31	*	7.062	7.062	14.125	13.750	5.375	4.750	14.500	6.062	9.500	7.500	4.875	.312	.468	1.812	8 @ .875	6.000	3.500	.500	.125	215
4...	R-37	*	7.937	7.187	15.125	14.125	6.125	5.750	15.750	7.000	11.500	9.250	5.875	.312	.468	2.062	8 @ 1.125	7.000	4.500	.750	.125	300
6...	R-45	*	8.687	8.062	16.750	15.500	7.000	7.500	18.750	9.000	15.000	12.500	8.312	.312	.468	2.500	12 @ 1.125	8.000	6.625	.750	.125	490
8...	R-49	*	9.250	9.250	18.500	17.250	9.125	9.250	21.750	11.000	18.500	15.500	10.625	.312	.468	2.812	12 @ 1.375	9.000	8.625	.750	.250	1095
10...	R-53	*	11.000	11.000	22.000	18.375	11.000	10.750	24.875	13.125	21.500	18.500	12.750	.312	.468	3.062	16 @ 1.375	9.500	10.750	.750	.250	1555
12...	R-57	*	11.750	11.750	23.500	20.375	12.250	12.000	28.000	15.000	24.000	21.000	15.000	.312	.468	3.437	20 @ 1.375	10.250	12.750	.750	.250	1935

\*To be specified by purchaser.  
Size 12" up to 900 lbs. A.S.A. use "DVS" Seal Vulcanized to plate. Rev. 10.25

The dimensions shown in the table are approximations and are for guidance purposes only. Casting and machining tolerances may vary from published sizes. Refer to the sales personnel over the order to confirm specific fitting sizing, and or provide a GA Drawing

# STANDARD RF X RF (FLANGED) FITTINGS

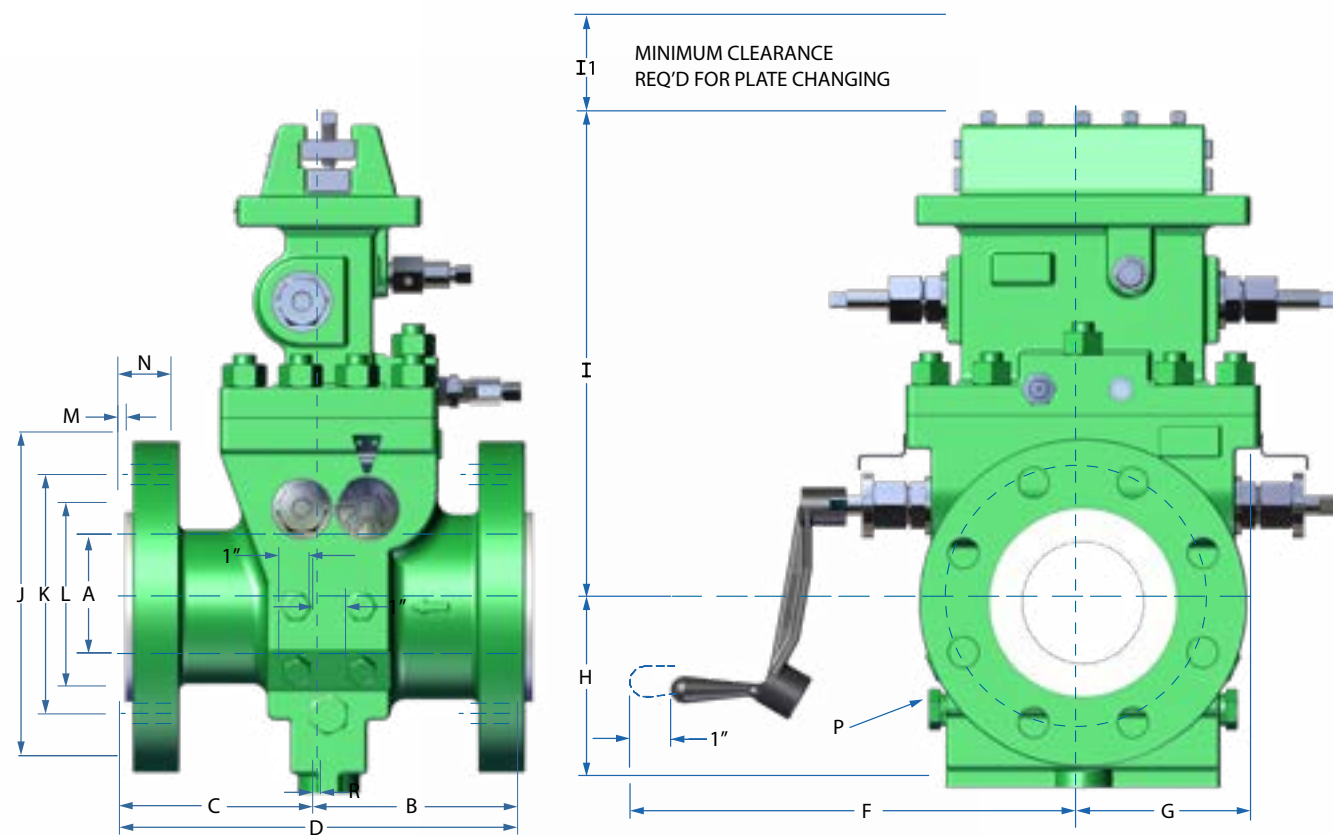

	Weight (LBS) Approx.	Upstream Face of Orifice Plate to Face of End	Downstream Face of Orifice Plate to Face of End	Face to Face Overall Diam.	Operating Clearance From Center	Body Clearance From Center	Centerline to Bottom	Centerline to Top	Clearance For Changing Plate	Flange Diameter	Bolt Circle Diameter	Diameter of Raised Face +.000-.500	Raised Face Height	Flange Thickness	Number and Diameter of Bolt-Studs (Per Flange)	Length of Bolt-Studs with 2 Hex. Nuts	Drain Plug Sizes	Orifice Plate	Weight (Pounds) Approximate
SIZE	A	B	C	D	F	G	H	I	I1	J	K	L	M	N			P	R	

Catalog No. 101DC 150 Lb. A.S.A. - Flange X Flange Standard Flange Facing - 275 P.S.I. (Gage) C.W.P. - Dual Seal																			
2...	2.067	5.250	5.250	10.625	12.875	4.250	3.750	13.250	5.562	6.000	4.750	3.625	.062	.750	4@ .625	3.250	.500	.125	110
3...	3.068	7.250	6.625	10.750	13.750	5.375	4.000	14.500	6.062	7.500	6.000	5.000	.062	.937	4@ .625	3.750	.500	.125	155
4...	4.026	7.187	7.187	11.000	14.125	5.875	4.500	15.750	7.000	9.000	7.500	6.312	.062	.937	8@ .625	3.750	.750	.125	255
6...	6.065	7.937	7.937	13.250	15.500	6.750	5.500	18.750	9.000	11.000	9.500	8.500	.062	1.000	8@ .750	4.000	.750	.125	295
8...	7.981	8.625	8.625	12.500	16.500	8.000	6.750	21.750	11.000	13.500	11.750	10.625	.062	1.125	8@ .750	4.250	.750	.250	385
10...	10.020	9.00	8.000	13.000	17.375	9.000	8.000	24.875	13.125	16.000	14.250	12.750	.062	1.187	12@ .875	4.750	.750	.250	520
12...	11.938	9.812	8.812	14.000	18.875	10.750	9.500	28.000	15.000	19.000	17.000	15.000	.062	1.250	12@ .875	4.750	.750	.250	730

Catalog No. 103DC 300 Lb. A.S.A. - Flange X Flange Standard Flange Facing - 720 P.S.I. (Gage) C.W.P. - Dual Seal																			
2...	2.067	5.250	5.250	10.625	12.875	4.250	3.750	13.250	5.562	6.500	5.000	3.625	.062	.875	8@ .625	3.500	.500	.125	115
3...	3.068	7.250	6.625	11.125	13.750	5.375	4.125	14.500	6.062	8.250	6.625	5.000	.062	1.125	8@ .750	3.750	.500	.125	175
4...	4.026	7.187	7.187	12.000	14.125	5.875	5.000	15.750	7.000	10.000	7.875	6.187	.062	1.250	8@ .750	3.750	.750	.125	230
6...	6.065	7.937	7.937	14.000	15.500	7.000	6.250	18.750	9.000	12.500	10.625	8.500	.062	1.437	12@ .750	4.000	.750	.125	380
8...	7.981	8.625	8.625	14.000	16.500	8.000	7.500	21.750	11.000	15.000	13.000	10.625	.062	1.625	12@ .875	4.250	.750	.250	550
10...	10.020	9.00	8.000	15.500	17.375	9.000	8.750	24.875	13.125	17.500	15.250	12.750	.062	1.875	16@ 1.000	4.750	.750	.250	725
12...	11.938	9.812	8.812	17.000	18.875	10.750	10.250	28.000	15.000	20.500	17.750	15.000	.062	2.000	16@ 1.125	4.750	.750	.250	1235

Catalog No. 105DC 600 Lb. A.S.A. - Flange X Flange Standard Flange Facing - 1440 P.S.I. (Gage) C.W.P. - Dual Seal																			
2...	2.067	5.250	5.250	10.625	12.875	4.250	3.750	13.250	5.562	6.500	5.000	3.625	.250	1.250	8@ .625	4.250	.500	.125	120
3...	3.068	7.250	6.625	13.375	13.750	5.375	4.125	14.500	6.062	8.250	6.625	5.000	.250	1.500	8@ .750	5.000	.500	.125	180
4...	4.026	7.187	7.187	13.250	14.125	6.125	5.375	15.750	7.000	10.750	8.500	6.188	.250	1.750	8@ .875	5.750	.750	.125	310
6...	6.065	7.937	7.937	16.000	15.500	7.000	7.000	18.750	9.000	14.000	11.500	8.500	.250	2.125	12@ 1.000	6.750	.750	.125	490
8...	7.981	8.625	8.625	17.500	16.500	8.000	8.250	21.750	11.000	16.500	13.750	10.625	.250	2.437	12@ 1.125	7.750	.750	.250	720
10...	10.020	9.00	8.000	17.250	17.375	9.000	10.000	24.875	13.125	20.000	17.000	12.750	.250	2.750	16@ 1.250	8.500	.750	.250	930
12...	11.938	9.812	8.812	18.875	18.875	10.750	11.000	28.000	15.000	22.000	19.250	15.000	.250	2.875	20@ 1.250	8.750	.750	.250	1440

Catalog No. 106DC 900 Lb. A.S.A. - Flange X Flange Standard Flange Facing - 2220 P.S.I. (Gage) C.W.P. - Teflon Seal																			
2...	2.067	5.250	5.250	14.000	12.875	5.750	4.250	13.750	5.562	8.500	6.500	3.625	.250	1.750	8@ .875	5.750	.500	.125	205
3...	3.068	7.250	6.625	14.000	13.750	5.750	4.750	14.500	6.062	9.500	7.500	5.000	.250	1.750	8@ .875	5.750	.500	.125	215
4...	4.026	7.187	7.187	15.000	14.125	6.125	5.750	15.750	7.000	11.500	9.250	6.188	.250	2.000	8@ 1.125	6.750	.750	.125	365
6...	6.065	7.937	7.937	16.625	15.500	7.000	7.500	18.750	9.000	15.000	12.500	8.500	.250	2.437	12@ 1.125	7.750	.750	.125	610
8...	7.981	8.625	8.625	18.375	17.250	9.125	9.250	21.750	11.000	18.500	15.500	10.625	.250	2.750	12@ 1.375	8.750	.750	.250	1275
10...	10.020	9.00	8.000	21.875	18.375	11.000	10.750	24.875	13.125	21.500	18.500	12.750	.250	3.000	16@ 1.375	9.250	.750	.250	1810
12...	11.938	9.812	8.812	23.375	20.375	12.250	12.000	28.000	15.000	24.000	21.000	15.000	.250	3.750	20@ 1.375	10.000	.750	.250	2270

\*To be specified by purchaser.  
Size 12" up to 900 lbs. A.S.A. use "DVS" Seal Vulcanized to plate. Rev. 10.25

The dimensions shown in the table are approximations and are for guidance purposes only. Casting and machining tolerances may vary from published sizes. Refer to the sales personnel over the order to confirm specific fitting sizing, and or provide a GA Drawing

# RTJ X RTJ (FLANGED) FITTINGS

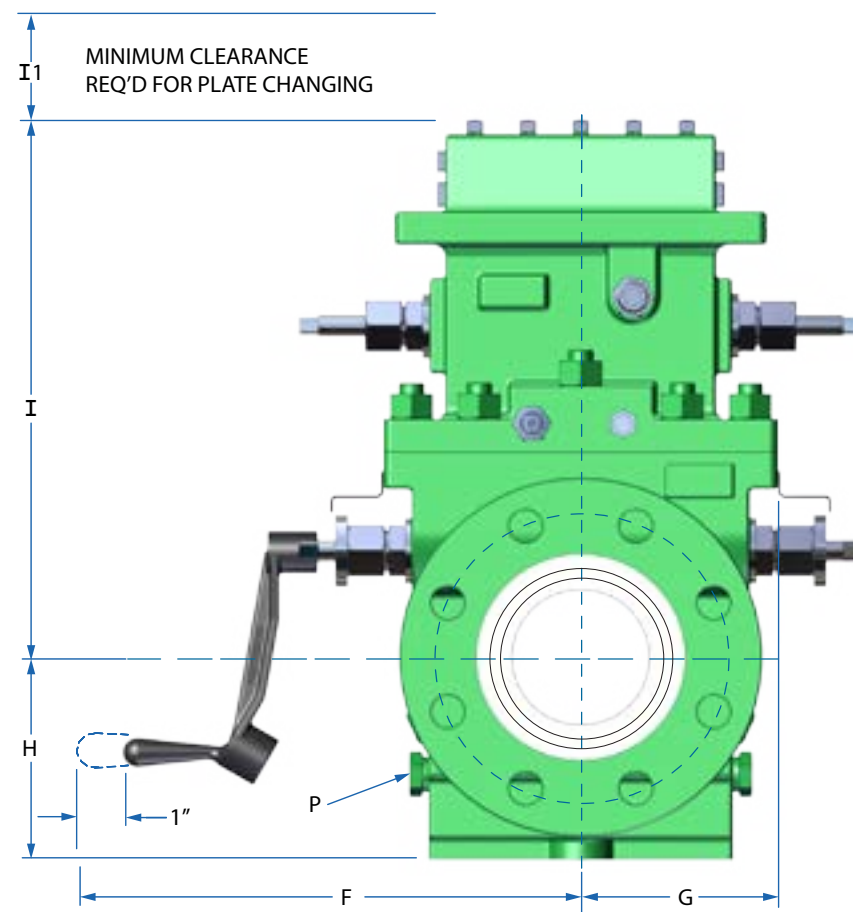
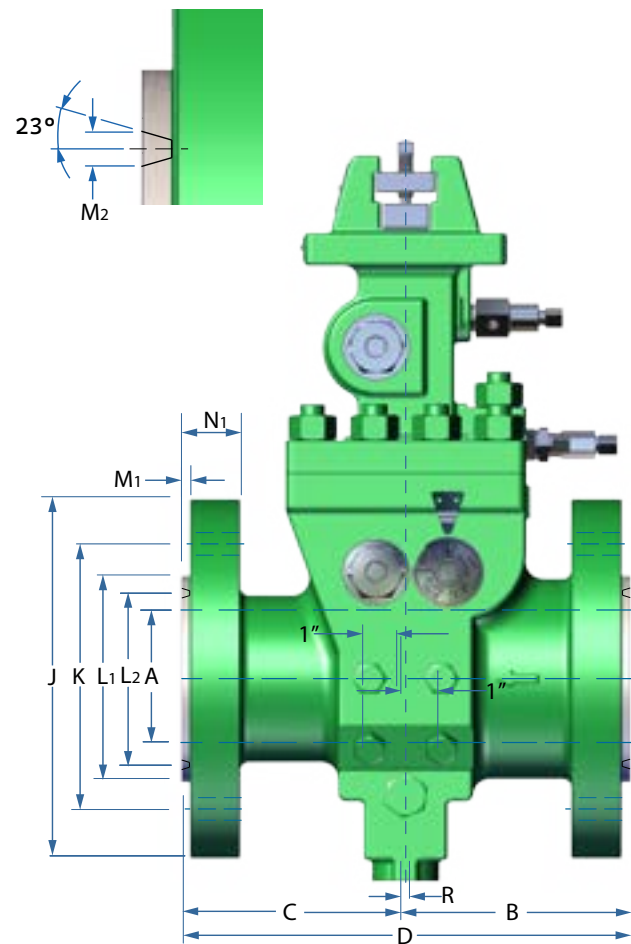

SIZE	Weight (LB)	Upstream Face of Orifice Plate to Face of End	Downstream Face of Orifice Plate to Face of End	Face to Face Overall Diam.	Operating Clearance From Center	Body Clearance From Center	Centerline to Bottom	Centerline to Top	Clearance For Changing Plate	Flange Diameter	Bolt Circle Diameter	Diameter of Raised Face +.000 - .500	Raised Face Height	Flange Thickness	Number and Diameter of Bolt-Studs (Per Flange)	Length of Bolt-Studs with 2 Hex. Nuts	Drain Plug Sizes	Orifice Plate Thickness	Weight (Pounds) Approximate
------	-------------	---	---	----------------------------	---------------------------------	----------------------------	----------------------	-------------------	------------------------------	-----------------	----------------------	--------------------------------------	--------------------	------------------	--	---------------------------------------	------------------	-------------------------	-----------------------------

Catalog No. 145DC 600 Lb. A.S.A. - Flange X Flange Ring - Joint Glange Facing Standard Flange Facing - 1440 P.S.I. (Gage) C.W.P. - Dual Seal																			
2...	2.067	5.250	5.250	10.625	12.875	4.250	3.750	13.250	5.562	6.500	5.000	3.625	.250	1.250	8@ .625	4.250	.500	.125	120
3...	3.068	7.250	6.625	13.375	13.750	5.375	4.125	14.500	6.062	8.250	6.625	5.000	.250	1.500	8@ .750	5.000	.500	.125	180
4...	4.026	7.187	7.187	13.250	14.125	6.125	5.375	15.750	7.000	10.750	8.500	6.188	.250	1.750	8@ .875	5.750	.750	.125	310
6...	6.065	7.937	7.937	16.000	15.500	7.000	7.000	18.750	9.000	14.000	11.500	8.500	.250	2.125	12@ 1.000	6.750	.750	.125	490
8...	7.981	8.625	8.625	17.500	16.500	8.000	8.250	21.750	11.000	16.500	13.750	10.625	.250	2.437	12@ 1.125	7.750	.750	.250	720
10...	10.020	9.000	8.000	17.250	17.375	9.000	10.000	24.875	13.125	20.000	17.000	12.750	.250	2.750	16@ 1.250	8.500	.750	.250	930
12...	11.938	9.812	8.812	18.875	18.875	10.750	11.000	28.000	15.000	22.000	19.250	15.000	.250	2.875	20@ 1.250	8.750	.750	.250	1440

Catalog No. 146DC 900 Lb. A.S.A. - Flange X Flange Ring - Joint Glange Facing Standard Flange Facing - 2160 P.S.I. (Gage) C.W.P. - Teflon Seal																			
2...	2.067	5.250	5.250	14.000	12.875	5.750	4.250	13.750	5.562	8.500	6.500	3.625	.250	1.750	8@ .875	5.750	.500	.125	205
3...	3.068	7.250	6.625	14.000	13.750	5.750	4.750	14.500	6.062	9.500	7.500	5.000	.250	1.750	8@ .875	5.750	.500	.125	215
4...	4.026	7.187	7.187	15.000	14.125	6.125	5.750	15.750	7.000	11.500	9.250	6.188	.250	2.000	8@ 1.125	6.750	.750	.125	365
6...	6.065	7.937	7.937	16.625	15.500	7.000	7.500	18.750	9.000	15.000	12.500	8.500	.250	2.437	12@ 1.125	7.750	.750	.125	610
8...	7.981	8.625	8.625	18.375	17.250	9.125	9.250	21.750	11.000	18.500	15.500	10.625	.250	2.750	12@ 1.375	8.750	.750	.250	1275
10...	10.020	9.000	8.000	21.875	18.375	11.000	10.750	24.875	13.125	21.500	18.500	12.750	.250	3.000	16@ 1.375	9.250	.750	.250	1810
12...	11.938	9.812	8.812	23.375	20.375	12.250	12.000	28.000	15.000	24.000	21.000	15.000	.250	3.750	20@ 1.375	10.000	.750	.250	2270

\*To be specified by purchaser.  
Size 12" up to 900 lbs. A.S.A. use " DVS" Seal Vulcanized to plate. Rev. 10.25

The dimensions shown in the table are approximations and are for guidance purposes only. Casting and machining tolerances may vary from published sizes. Refer to the sales personnel over the order to confirm specific fitting sizing, and or provide a GA Drawing

# DUAL CHAMBER ORIFICE FITTINGS

# DUAL CHAMBER ORIFICE FITTING

2" Through 16"  
ANSI Class 150 Through Class 900  
Parts List and Materials



RECOMMENDED SPARE PARTS FOR ONE YEAR OPERATION  
- PRICES ON APPLICATION-

Quantity	Part Number	Description	Material
1	7319-XX 7319SS-XX	SLIDE VALVE GEAR SHAFT	CS (PLATED) STAINLESS STEEL
5 3	54NIT-XX 54HNBR-XX 54TEF-XX 54DEL-XX	ORIFICE PLATE SEALING UNIT "DVS" (DVS BONDED ORIFICE PLATES ONLY OFFERED 12" AND UP)	HNBR, NITRILE, TEFLON, CARBON STEEL, STAINLESS STEEL, ALUMINUM.  ADDITIONAL MATERIAL AVAILBLE UPON REQUEST.  (ALL METAL SEAL RINGS AVAILABLE IN SEVERAL MATERIAL EX, CARBON STEEL, STAINLESS STEEL, ALUMINUM, ETC.)
5	7325-XX 7325-XX-RK	SEALING BAR GASKET	C4430 AND/OR C4439  C4430 --> 1500-600 CLASS C4439 --> 900-2500 CLASS  PCB90 USED ON 1500-2500 CLASS
2	7218 7218SS	CLAMPING BAR SCREWS	ALLOY STEEL STAINLESS STEEL
1	7322-XX 7322-XX-RK	SLIDE VALVE SEAT TOP GASKET	C4430 AND/OR C4439  C4430 --> 150-600 CLASS C4439 --> 900-2500 CLASS  PCB90 USED ON 1500-2500 CLASS
2	7316 7316SS	BEARING PLUG AND STUFFING BOX GASKET	BERILLIUM COPPER STAINLESS STEEL (STANDARD)
1 - SET (VARIES WITH SIZE)	7308-XX	PACKING SLEEVES (1/16", 1/8", 3/16", 1/4", 3/8", 1/2")	TEFLON (PTFE) (SEE NOTE)
1 - SET (OF 15)	7308-14	BEARING PLUG AND STUFFING BOX CENTERING RINGS	TEFLON (PTFE)
3 BOXES	6508 6508-340 6508-104	SLIDE VALVE LUBRICANT (SPECIAL LUBRICANTS AVAILABLE FOR SPECIAL APPLICATIONS UPON REQUEST SUCH AS HIGH TEMPERATURE (BLACK) GREASE, AND LOW TEMP (CLEAR/WHITE) GREASE.)	TYPE B 800 TYPE B 340 H2S TYPE B #104 GREASE (HIGH -TEMP) PRECISION FLOW STANDARD (0-450F)

- (\*) SCHEDULE OF PIPE REQUIRED
- X = REPLACE WITH SIZE REQUIRED
- NOTE: USE SS WHEN STAINLESS IS REQUIRED (EX: 7316SS)

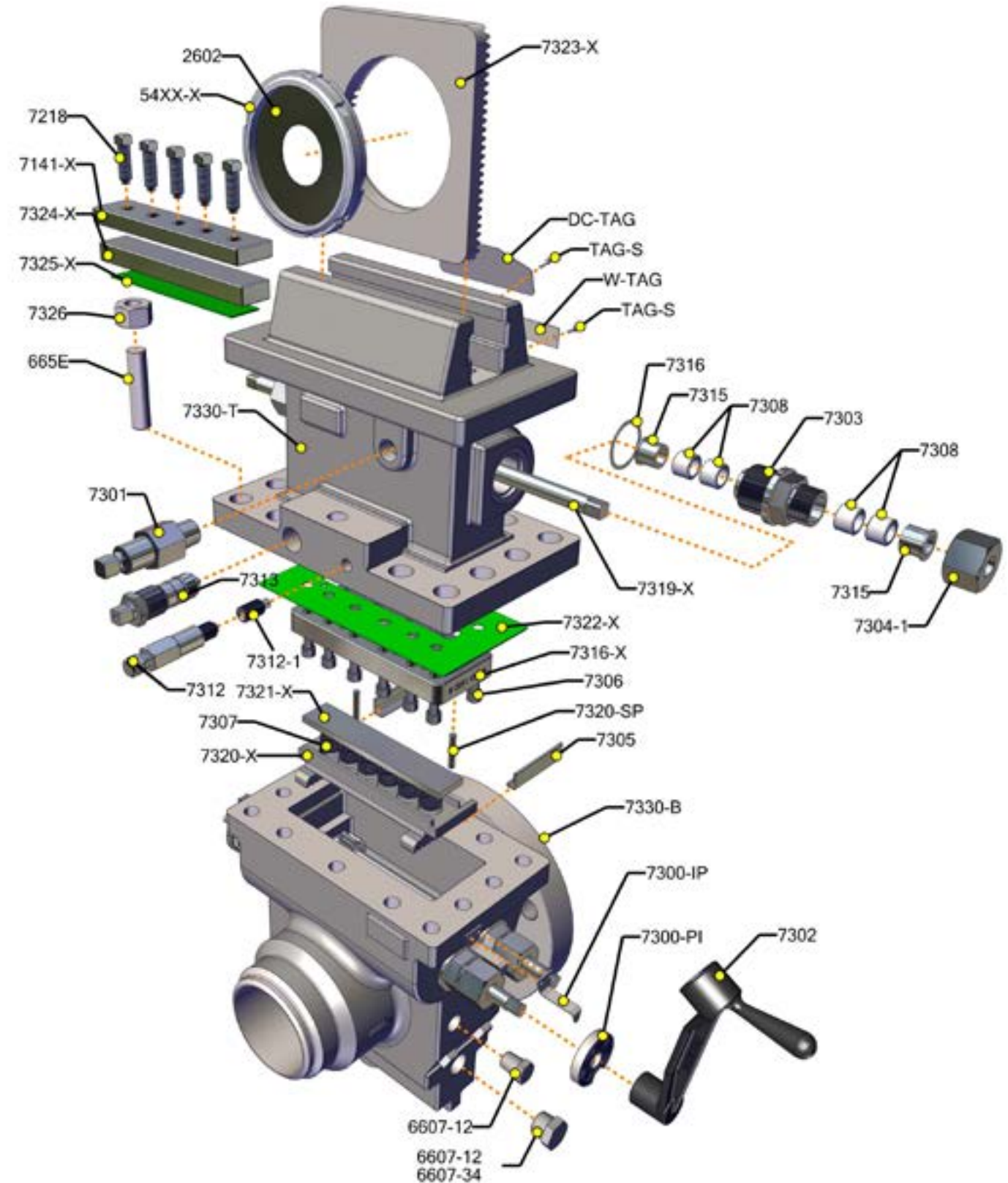

## Exploded Parts View

# Meter Tube Allowable W.P. @250°F Design Factors by Location and Construction

Table1 A-106 Gr. B, A-53, API-5L (No Corrosion Factor used)

Pipe Size	Pipe ID / Shed.	Type - A & B* Class 1 & 2 F = .60	Type - C Class - 3 F = .50	Type D Class - 4 F = .40
2"	2.067	40 (std)	2725	1820
	1.939	80 (X-Stg)	3855	2570
	1.689	160	6070	4045
3"	3.068	40 (std)	2595	1728
	2.900	80 (X-Stg)	3600	2400
	2.626	160	5260	3504
	2.300	XX-Stg	7200	4800
4"	4.026	40 (std)	2215	1475
	3.826	80 (X-Stg)	3145	2130
	3.438	160	4960	3305
	3.152	XX-Stg	6295	4195
6"	6.065	40 (std)	1775	1185
	5.761	80 (X-Stg)	2740	1830
	5.189	160	4555	3035
	4.897	XX-Stg	5480	3655
8"	8.071	30	1350	900
	7.981	40 (Std)	1570	1045
	7.625	80 (X-Stg)	2435	1625
10"	10.136	30	1200	800
	10.020	40 (Std)	1430	955
	9.564	80	2320	1545
12"	12.090	30	1090	725
	11.938	40 (Std)	1340	895
	11.376	80 (X-Stg)	2265	1510
16"	15.250	30 (Std)	985	660
	15.000	40 (X-Stg)	1315	875
	14.688	60	1725	1150
18"	17.250	STD	875	583
	17.000	XH	1176	778
	14.876	40	1311	874
20"	19.000	XH	1050	700
	18.814	40	1245	830
	17.938	80	2165	1443

Note: For use in production, transmission, and distribution of natural gas.  
Note: Allowable working pressure of 35,000 lbs yield pipe designed to B-31.8 code

UNIVERSAL PART NO. UNIVERSAL PART N	DESCRIPTION	NUMBER & SIZE REQUIRED								MATERIAL
		2"	3"	4"	6"	8"	10"	12"	16"	
*7313	EQUALIZER VALVE (COMPLETE)	1	1	1	1	1	1	1	1	CARBON STEEL (BODY)
*7313-IGP	STEM	1	1	1	1	1	1	1	1	316 STAINLESS STEEL
*7313-1HP	PACKING ADJUSTMENT NUTS	1	1	1	1	1	1	1	1	316 STAINLESS STEEL
*7313-113P	BALL	1	1	1	1	1	1	1	1	HARDEN CHROME-STEEL
*7313-1KP	PACKING WASHER	1	1	1	1	1	1	1	1	316 STAINLESS STEEL
*7313-1TP	TEFLON PACKING	1	1	1	1	1	1	1	1	TEFLON SLEEVES
*7302	DUCTILE IRON OPER. WRENCH	1	1	1	1	1	1	1	1	DUCTILE IRON
7321-X	VALVE STRIP	1	1	1	1	1	1	1	1	17-4 PRECIP. HARDNESS STAINLESS STEEL
7330-B	LOWER ORIFICE BODY	1	1	1	1	1	1	1	1	A-216-WCC CRBN STL (OR)
7319-X	VALVE SHAFT WITH PINIONS	1	1	1	1	1	1	1	1	316 STAINLESS STEEL
		1	1	1	1	1	1	1	1	CARBON STEEL
*7300-PI	SLIDE VALVE POSITION IND.	1	1	1	1	1	1	1	1	CARBON STEEL
*7300-IP	SLIDE VALVE POSITION PNTR.	1	1	1	1	1	1	1	1	ALUMINUM
7319-X	SHFTPINION ASSEMBLY - LWR	1	1	1	1	1	1	1	1	CARBON STEEL
7323-X	PLATE CARRIER	1	1	1	1	1	1	1	1	CARBON STEEL
54DS-XX	ORIFICE SEAL (REPLACEABLE)	1	1	1	1	1	1	1	1	AS ORDERED
54TS-XX	ORIFICE PLATE SEALING UNIT (W/OUT OR. PLT) ALT TEFLON SEAL	1	1	1	1	1	1	1	1	VULCNZD TO ORIFICE PLT (12" & UP)
7324-X	SEALING BAR	1	1	1	1	1	1	1	1	CARBON STEEL
7325-X	SEALING BAR GASKET	1	1	1	1	1	1	1	1	GRAPHITE ASBESTOS
*7301	BLEEDER VALVE ASSEMBLY	1	1	1	1	1	1	1	1	CARBON STEEL PLATED
*7301-CP	BLEEDER VALVE BODY	1	1	1	1	1	1	1	1	CARBON STEEL
*7301-DP	EQUALIZER VALVE CONE PT. INR		1	1	1	1	1	1	1	316 STAINLESS STEEL
*7301-EP	"O" RING	1	1	1	1	1	1	1	1	VITON
7218	CLAMPING BAR SCREWS	4	4	5	6	7	8	10	12	CARBON STEEL CAD PLATED
		4	4	5	6	8	8	10	12	316 STAINLESS STEEL
7141-X	CLAMPING BAR	1	1	1	1	1	1	1	1	C/STEEL (CHEM TREATED)
24XX	ORIFICE PLATE	1	1	1	1	1	1	1	1	AS ORDERED
7330-T	ORIFICE TOP	1	1	1	1	1	1	1	1	A-216 WCC CRBN STL
*7307	VALVE SPRINGS	4	4	4	6	6	6	7	10	STAINLESS STEEL
*7305	SLIDE VALVE GUIDES	2	3	3	2	2	2	2	2	316 STAINLESS STEEL
7320-X	VALVE CARRIER	1	1	1	1	1	1	1	1	316 STAINLESS STEEL
*7320-SP	DOWELL PIN STOPS	2	2	2	2	2	2	2	2	316 STAINLESS STEEL
7318-XX	SEAT	1	1	1	1	1	1	1	1	17-4 PRECIP HARDNESS S.S
7322-X	VALVE SEAT GASKET	1	1	1	1	1	1	1	1	KLINGER 4140
*7306	SEAT SCREWS	8	10	11	14	16	18	20	26	CARBON STEEL
7303	UPPER BEARING PLUG***	1	1	1	1	1	1	1	0	CARBON STEEL PLATED
7304	UPPER STUFFING BOX (BODY ONLY)	1	1	1	1	1	1	1	2	CARBON STEEL PLATED
7304	LOWER STUFFING BOX (BODY ONLY)	2	2	2	2	2	2	2	4	CARBON STEEL PLATED
7303	LOWER BEARING PLUG***	2	2	2	2	2	2	2	0	CARBON STEEL PLATED
*7316	STUFFING BOX GASKET	6	6	6	6	6	6	6	6	Annealed Cooper
7312	GREASE GUN ASSEMBLY	1	1	1	1	1	1	1	1	CARBON STEEL PLATED
*7312B	BODY	1	1	1	1	1	1	1	1	CARBON STEEL PLATED
*7312-S	STEM	1	1	1	1	1	1	1	1	CARBON STEEL PLATED
*7312-1	BALL CHECK VALVE	1	1	1	1	1	1	1	1	STAINLESS STEEL
*7304-1	STUFFING BOX PACKING NUT	6	6	6	6	6	6	6	6	CARBON STEEL
*7308-XX	TEFLON PACKING STUFFING	** (1)	** (1)	** (1)	** (1)	** (1)	** (1)	** (1)	** (1)	TEFLON SLEEVES
7308-14	BOX CENTERING RINGS	15	15	15	15	15	15	15	15	TEFLON SLEEVES
*7314	STUFFING BOX GLAND	3	3	3	3	3	3	3	3	316 STAINLESS STEEL
*7315	RETAINER	3	3	3	3	3	3	3	3	316 STAINLESS STEEL
6607-12	1/2" NPT Plugs (For Tap Holes And Drain)	10	10	10	8	8	8	8	8	ASTM A 105
6607-34	3/4" NPT Plugs (For Drain)	-	-	-	2	2	2	2	2	ASTM A 105

NOTE. X xx SUBSTITUTE SIZE @ 2 = 2"

\* Indicates parts are Interchangeable (2" - 12") Rev. 06.01.25

\*\*\*Depending on the year of manufacture, the fitting may feature dual shafts, resulting in no bearing plugs (0).

# Notes Continued

# SEAL RINGS – AGA 3 14.3 LATEST EDITION

For Yields other than 35,000 lbs, substitute new yield into formula.

$$P = d \times F \times E \times T$$

Definitions:

P = Design pressure, psi:

S = 35,000 psi, minimum yield strength

D = Normal outside diameter, inches

t = Normal wall thickness in inches

E = 1.000 Longitudinal joint factor

T = 1.000 Temperature factor for derating (250 o F or Less)

F = Construction design factor (see below)

\*F = .60, Type B Class 2: for fringe area around towns and cities. Use this factor for meter tubes in type A, class 1 locations.

F = .50, Type C, Class 3: for commercial and residential housing areas, compressor stations, etc.

F = .40, Type D, Class 4: for areas with multistory buildings, dense traffic, other utilities, etc.

\* Title 49 C FR 192 (D.O.T. – 192.111)

Typical installation for gas transmission, however consult applicable code for actual design factor. (see table II)

Table II

Pipe Yield	Multiplier
30,000 lbs	.857
42,000 lbs	1.200
46,000 lbs	1.314

Making sure your new or old fitting meets AGA 3 14.3 Latest Edition standards while ensuring repeatability and longevity of a single Seal Ring use.

- **No Beta Restrictions:** Ensures interchangeability of plates and plate carriers.
- **Wide Compatibility:** Fits most Single and Dual Chamber Orifice fittings that are either Old Style or the 14.3 New Style Notched with a Modified Carrier.
- **Universal Plate Acceptance:** Accepts Standard 500 Series Universal Orifice Plates.
- **Easy Replacement:** Features several options in materials from Nitrile, HNBR, Viton (FKM), Teflon (PTFE), 2-Piece SS, Plated CS, 6061AL, etc.... Seal Rings that allow field replacements without special tools.
- **Simple Alignment:** Requires no special assembly for alignment.

### Tap Hole Spacing

Meter tubes using flange taps shall have the center of the upstream pressure tap hole placed 1 inch from the upstream face of the orifice plate. The center of the downstream pressure tap hole shall be 1 inch from the downstream face of the orifice plate. If the pressure tap holes are located by measuring from the bearing face of a flange, allowance must be made for the gasket or plate holding device used. Each tap hole shall be located at the 1-inch dimension within the recommended tolerances. A maximum diameter ratio (Br) of 0.75 is advised for the design of new installations.

### Seal Ring Test / Tap Hole Communications

In orifice fittings, there is the possibility that some fluid may bypass the orifice plate. Tests shall be conducted after the meter run has been pressure-tested in accordance with the relevant code to ensure the following:

- No differential pressure tap communication or leakage exists.
- No holding or sealing device fluid bypass exists.

### Tube Conditions

The internal surface roughness of the meter tube should be measured at approximately the same axial locations as those used to determine and verify the meter tube internal diameter. A minimum of four roughness measurements shall be made. The mean (arithmetic average) of these four or more roughness measurements is defined as the meter tube internal surface roughness. The mean meter tube internal surface roughness may not exceed the following specifications to meet the uncertainty values:

- **300 micro inches R** if the diameter ratios (Br) are less than 0.6.
- **250 micro inches R** if the diameter ratios (Br) are greater than or equal to 0.6.



WE OFFER BOTH OLD STYLE, AND 14. 3 NEW STYLE "NOTCHED" SEAL RINGS IN MATERIALS BELOW

#### NITRILE SEAL RING PHYSICAL PROPERTIES:

HARDNESS SHORE A	70-75	ASTM D 2240
TENSILE STRENGTH PSI	2250 (+/-) 100	ASTM D 412
ELONGATION AT BREAK (%)	350 (+/-) 50	ASTM D 412
TEAR STRENGTH (LB/IN)	199	ASTM D 624
TEMPERATURE RESISTANCE	-4°F TO 249°F	

#### HNBR SEAL RING PHYSICAL PROPERTIES:

HARDNESS SHORE A	70-75	ASTM D 2240
TENSILE STRENGTH PSI	2150 (+/-) 100	ASTM D 412
ELONGATION AT BREAK (%)	225 (+/-) 50	ASTM D 412
TEAR STRENGTH (LB/IN)	171	ASTM D 624
TEMPERATURE RESISTANCE	-35°F TO 293°F	

#### FKM (VITON) SEAL RING PHYSICAL PROPERTIES:

HARDNESS SHORE A	70-75	ASTM D 2240
TENSILE STRENGTH PSI	1615 (+/-) 100	ASTM D 412
ELONGATION AT BREAK (%)	250 (+/-) 50	ASTM D 412
TEAR STRENGTH (LB/IN)	125	ASTM D 624
TEMPERATURE RESISTANCE	-4°F TO 455°F	

#### TEFLON (PTFE VIRGIN) SEAL RING PHYSICAL PROPERTIES:

HARDNESS SHORE A	55-60	ASTM D 2240
TENSILE STRENGTH PSI	3625	ASTM D 412
ELONGATION AT BREAK (%)	270	ASTM D 412
TEAR STRENGTH (LB/IN)	621°F	ASTM D 624
TEMPERATURE RESISTANCE	-350°F TO 500°F	

## Description

The DEL-SEAL 2.0 is an innovative and new design in seal ring technology. It is a seal ring that provides superior performance and durability compared to Teflon and traditional seal ring materials. It reduces gas permeation and promotes higher dimensional stability. With its unique o-ring design, it performs in harsh environments where other elastomer's fail. The DELSEAL is a fully machined product, rather than a molded seal. The DELSEAL comes standard with Viton(FKM) or peroxide cured Buna o-rings and can be easily changed (if needed) with standard o-ring sizes. Other elastomer's can be used based on service requirements. This simple snap together design allows for quick and easy orifice plate changes.



### AVAILABLE SIZES:

SIZES 2" thru 16" in all pipe schedules and all plate thickness.  
Custom I.D.'s and plate thickness available upon request

Our Idealogy with this piece:

"To Simplify the Field Tech's Job with Performance Quality Products!"

ASTM PROPERTY	UNIT (EA)	DEL SEAL
Specific Gravity		1.14 - 1.15
Tensile Strength	PSI	9,500 - 11,000
Tensile Elongation	%	45 - 55
Tensile Modulus	PSI	375,000 - 475,000
Compressive Strength (@10% OFF SET)	PSI	12,000 - 14,000
Flexural Strength	PSI	14,000 - 16,000
Shear Strength	PSI	8,000 - 9,000
CONT. Service Temp.	DEG. F	230
INTER. Service Temp.	DEG. F	330

# PRECISION DEL SEAL 2.0

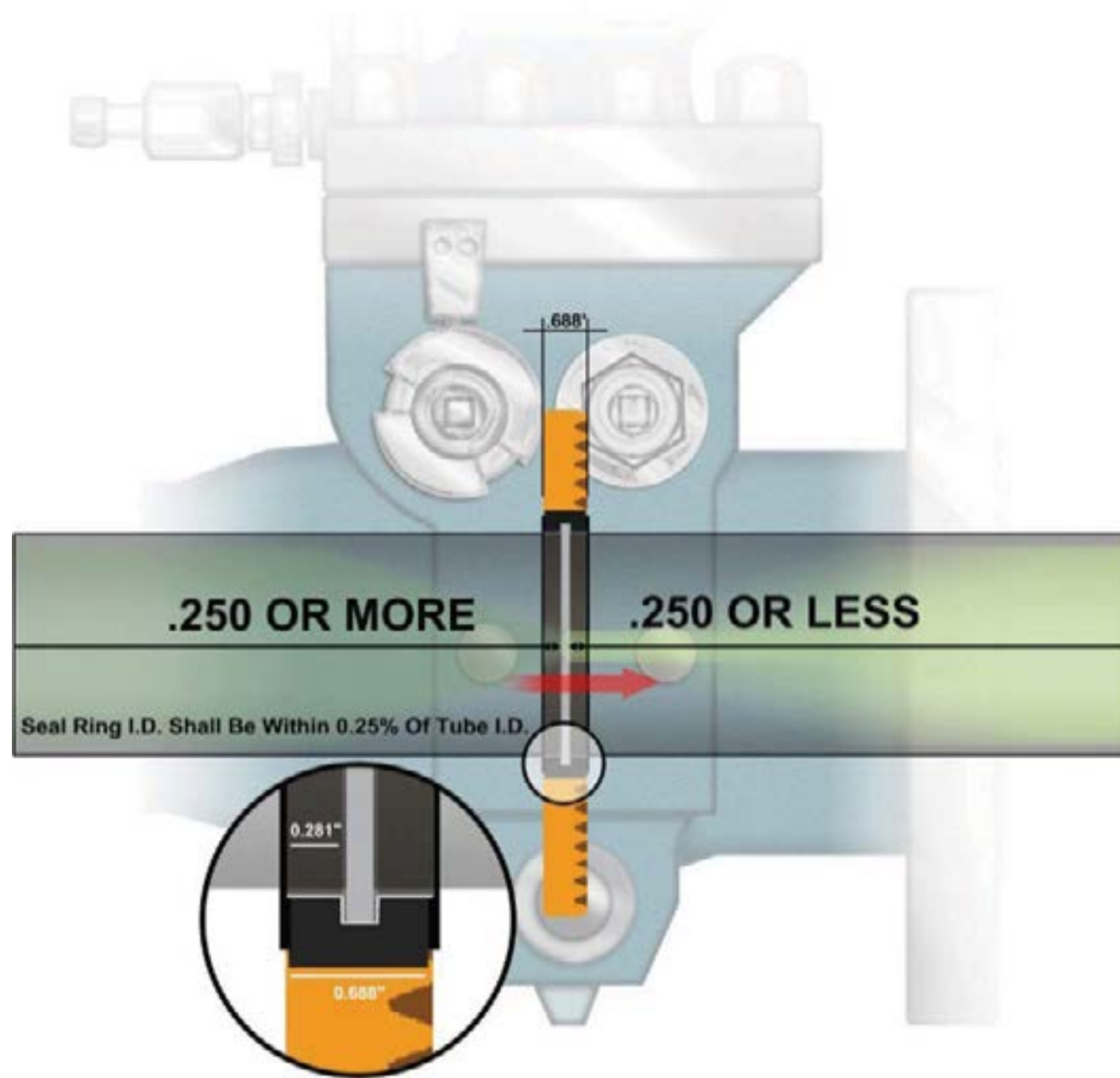

432-381-5131  
precisionflow.com  
2600 W 81st Street  
Odessa, Texas  
79764